

TigermagEP

Technical Specifications

FM626 3A Sanitary Electromagnetic Flowmeter



DESCRIPTION

The Tigermag EP FM626 with 3A approval is a microprocessor-based electromagnetic flowmeter for food and pharmaceutical applications. The sensor and the transmitter are integral and enclosed in a NEMA-4X & NEMA-7 explosion-proof housing.

The sensor has a FDA approved *Tefze*®-lined stainless steel flow tube and 316SS electrodes are standard. Temperatures up to 266°F allow for clean or steam in place.

PRINCIPLE OF OPERATION

The Model 626 magnetic flowmeter is based on Faraday's Law which states that the voltage induced in a conductor moving through a magnetic field is proportional to the velocity of that conductor. The magnetic flowmeter will measure liquids possessing conductivities greater than 5 micromhos.

APPLICATIONS

The Model 626 high signal frequency makes it ideally suited to applications with high levels of inherent noise including: Process Chemicals, Acid, Alkalies, Cooling Water, nearly any conductive liquid.

AC/DC POWER

The FM626 utilizes an advanced switching power supply that accommodates voltages from 77 - 265 Vac 50/60 Hz (12-60 Vdc optional).

CERTIFIED ACCURACY

Each TigermagEP™ is wet-flow calibrated in Sparling's NIST-traceable primary flow lab. A certificate of accuracy is furnished with each meter.

STANDARD FEATURES

- Standard 0.5% accuracy
- Sizes available from 1" - 4"
- NEMA-4X & NEMA-7 explosion proof enclosures
- Forward, reverse and net totalization
- Empty pipe detection
- 3 outputs: 4-20 mA, scaled totalizer pulse and frequency
- Digital port: RS232
- Diagnostics include current ramp, coil drive check and input simulator
- Sampling frequency to 100 Hz for accurate measurement of fluids with high levels of inherent noise
- PZR - Positive Zero Return
- Programmable high & low flow alarms
- Non-volatile EEPROM memory
- 2-line, 16 character backlit display
- Mag-Command™ meter programming
- User-selectable damping & low flow cutoff
- Approvals include: CSA, 3A, FM
- Pending approvals include: CE
- Rotatable modular display



SPARLING

DIAGNOSTICS

The TigermagEP's unique diagnostic functions eliminate the need for a technician to carry test equipment or open the housing. Current ramp, complete coil check and true front-end input simulator may be activated in Mag-Command™ without opening the enclosure. This is especially important in hazardous areas and aggressive plant environments.

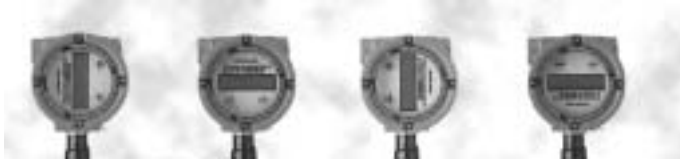

LARGE BACKLIT ROTATABLE DISPLAY

The large 16 character, 2-line backlit transmitter display is rotatable 360° in 90° increments ensuring easy reading in any orientation.

INSTALLATION

The Model 626 meter must be mounted at a point in the line which is always full of process liquid under flowing conditions.

Only three diameters of straight pipe length are required from the center of the meter to normal obstructions to obtain specified accuracies.

E²PROM NON-VOLATILE MEMORY

and circuitry eliminates the need for a back-up battery and eliminates the need to reprogram if the electronics module is replaced or exchanged. Meter identification (tube ID, serial number, K, offset, etc.) is stored on an E²PROM chip independent of transmitter electronics. The E²PROM chip has lifetime data retention.

EMPTY PIPE DETECTION - Standard

The Sparling TigermagEP™ is designed to detect absence or inadequate volume of process fluid in the pipe and will hold the output signal to 4mA or zero. This feature does not require any hard wiring as it is a software selection. One of the most important values of this feature is that it prevents false totalization possible with other meters under partially filled pipe conditions.

EASE OF COMMUNICATIONS

The TigermagEP™ is programmable with Mag-Command or Hart Protocol. 4-20mA, RS232 or RS485 outputs give you flexibility when interfacing with your DCS.

HI-Z CIRCUITRY

The Sparling TigermagEP™ provides superior performance in liquids which tend to deposit non-conductive coatings. The TigermagEP™ utilizes Hi-Z circuitry which produces a high input impedance to the transmitter's pre-amplifier (10¹² ohms). The impedance of the coating is negligible as compared to the impedance of the receiving instrument. The voltage drop across the electrode coating will also be negligible. This eliminates the need for electrode cleaners.

TWO FLOW ALARMS

Fault alarms can be configured with alarm set points between 0-99% of flow for each alarm. Open collector output turns on above programmed set point.

PZR - Positive Zero Return

Designed and built into the TigermagEP™ is an electronic circuit which is activated by an external contact closure indicating to the meter that it should drive the output signal to 4 mA or zero. An example of where this may be used is where the lines go empty when the pump or valve is shut down. Clean in place can be performed without changing the totalizers

REMOTE MOUNTED TRANSMITTER

Remote mounting of the electronics is required for high temperature operation or when pipe vibration is excessive. Interconnecting cable is supplied between the sensor and transmitter enclosure. Also supplied is a sensor mounted NEMA-7 rated junction box in which coil and electrode connections are made. An optional bracket for pipe mounting is available.

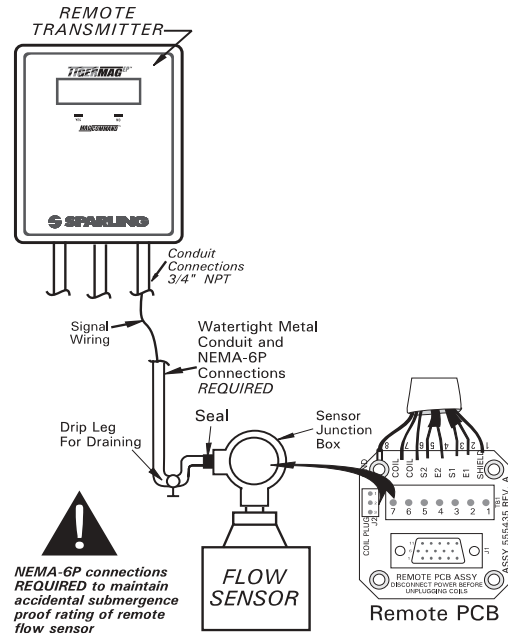

The TigermagEP™ remote enclosure features a larger sized (8mm) 16 digit 2-line backlit display. The meter is programmed using Mag-Command. Hall-effect switches are accessed from outside the enclosure... no need to open!

OPTIONAL 2 STAGE BATCH CONTROLLER



FLOWRATES & DIMENSIONS

Table 1 - Flow & Dimensions

Meter Size Inches	Mating Flange Size	Dimensions				Flowrates - GPM - Full Scale		
		A	B	C	D	1 fps	3 fps	33 fps
1	1	4.12	2.375	9.125	7.88	1.3	4	42
1.5	1.5	4.12	3.50	10.25	9.00	3.7	11	120
2	2	4.12	3.50	10.25	9.00	7.2	22	239
2.5	2.5	4.12	4.00	10.75	9.50	12	36	398
3	3	8.00	4.50	11.25	10.00	18	54	598
4	4	8.00	6.625	13.375	12.12	33	99	1088

C ±.0125

Integral

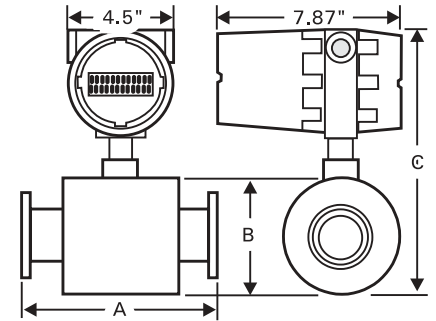

Remote

▼ Sensor

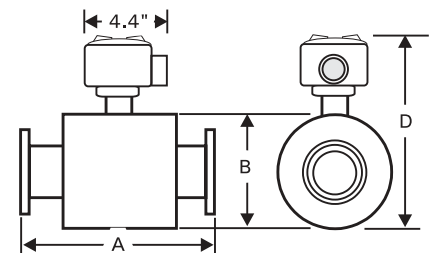

▼ Transmitter Enclosure

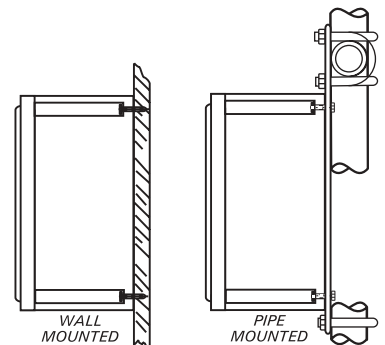
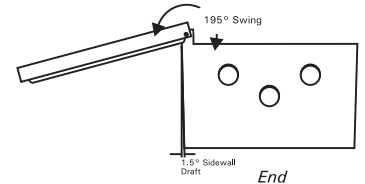
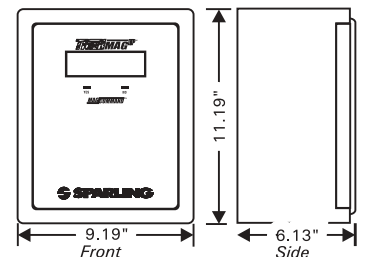

HOW TO ORDER A TIGERMAG EP MODEL 626-S

Base Model Number
FM626- TigermagEP

Size

OF = 1", OG = 1.5", O2 = 2", OH = 2.5", O3 = 3", O4 = 4"

Table 3 - Liner Material

4 Tefzel® / stainless steel housing

Table 4 - Electrode Material

1 316SS	5 Tantalum
2 Hastelloy C	7 Platinum
3 316SS Bullet Nosed	8 Zirconium
4 Titanium	9 Monel

Table 5 - Mounting

S Sanitary Tri Clamp Fitting

Table 6 - Transmitter and Mounting

0 Integral NEMA-4X/NEMA-7 enclosure
 3 Remote NEMA-4X/NEMA-7 enclosure, 15' cable, accidental submergence proof sensor
 6 Remote NEMA-4X enclosure, 15' cable, with accidental submergence proof sensor
 B Remote NEMA-4X enclosure with Batcher. (Includes: 15' cable, large display, start/stop/reset switches, LED status indicators, with accidental submergence proof sensor)

Table 7 - Power Supply*

0 77-265 VAC Power
 1 12-60 VDC Power

Special Notes for Construction

- ___ Hart® protocol (KP602 programmer available)
- ___ 485 Communications port
- ___ High temperature coils - required for temperatures over 266°F (Must be ordered with a remote mount option from Table 6) Tefzel® liner-max temp: 300°F @ 100 psi & 266°F to 300 psi
- ___ Special cable length (over 15 feet - Max. 100 ft.)
- ___ Alarm with relay contacts (remote mount only)

*FM approval is up to 120 volts

FM626-__ 4 __ S __ __

STANDARD SPECIFICATIONS

Accuracy: (Frequency Output)	1.0 ⁻ -4.0 ⁺ 0.25% of span (≤ 50% of span) (1-3 fps) 0.5% of flowrate (≥ 50% of span) (1-3 fps) 0.1% of span (≤ 20% of span) (3-33 fps) 0.5% of flowrate (≥ 20% of span) (3-33 fps)
Temperature Effect:	±0.025 % FS/°C
Full Scale Ranges:	From 0-3 to 0-33 ft/sec.
Repeatability:	±0.1% full scale
Electrodes:	Stainless steel standard (others available)
Liner:	Tefzel®
Outputs:	1) Isolated analog 4-20 mAdc into 800 ohms(std); 2) scaled pulse 24 Vdc with selectable 12.5/25/50/100 ms on time, max. freq. 60 Hz; 3) 0-1000 Hz freq., for 0-100% flow rate. 15 Vdc; 4) two flow alarms; 5) fault, with open collector; 6) RS232 communication; 7) flow direction with open collector; 8) Positive Zero Return (PZR) for external relay contacts. Outputs 2 & 3 can be open collector if required.
Mag-Command™:	Selection and change of meter parameters by magnetic probe without opening the enclosure.
Display:	2-Line, 16 Digit Alphanumeric backlit display (rate and total). Modular, rotatable 360° in 90° increments.
Conductivity:	Minimum 5 micromho/cm
Minimum Velocity:	0.3 fps (0.1 mps)
Power Requirements:	*77 - 265 Vac 50/60 Hz (12-60 Vdc optional)
Power Consumption:	Less than 20 VA.
Enclosures:	Transmitter: Cast aluminum epoxy coated. Integral (NEMA-7/NEMA-4X) and/or remote mounted (NEMA-4X). Sensor Housing: Polished 304 SS
Electrical Rating:	FM – Class I, Div. 1, Groups B, C, D; Class II, Div. 1, Groups E, F, G (150 psi integral mount) CSA Approved for Class 1, Division 2, Cenelac (opt.), CE (pending)
Pre-amp Impedance:	10 ¹² ohms minimum.
Ambient Temp:	-20° to 140°F (-30° to 60° C) Display may darken over 158°F (70°C)
End Connections:	Sanitary Tri-Clamp Fittings
Process Temp:	Integral Mount: Tefzel® -40 to 266°F Remote Mount(opt) Tefzel®(to 300 psi) -40 to 266°F High Temp. Coils (opt) Tefzel®(to 100 psi) -40 to 300°F
Selectable Damping:	0-99 sec.
Pressure Rating:	Tefzel® Sensor: 300 psi
Low Flow Cut-off:	Selectable 0-9% of F.S.
Options:	<ul style="list-style-type: none">• Remote Mounted NEMA-4X Enclosure• Remote Two-Stage Batching Transmitter• Electrode Materials: Titanium, Hastelloy C, Monel, Zirconium, Tantalum, Platinum• 12-60 Vdc operation• Digital Communications (HART Protocol)• Accidental Submergence proof sensor (remote mount only)• RS485 Communication• 0-20mA Output• Approvals: CE (pending)• Alarm with relay contacts (remote mount only)

MODEL 626-S SPECIFICATIONS

1.0	The magnetic flowmeter shall be microprocessor-based and shall be mounted between sanitary fittings. It shall indicate, totalize, and transmit flow in full pipes.
1.1	The magnetic flowmeter shall utilize DC bi-polar pulsed coil excitation, operating at frequencies up to 100 Hz and automatically re-zeroing after every cycle.
1.2	The accuracy shall be at least 0.5% (≥ 50% of span) of flowrate over a 33:1 turndown at all flow rates above 1 fps. Accuracy shall be verified by calibration in a flow laboratory traceable to the U.S. National Institute of Standards and Technology.
1.3	The flow sensor liner shall be Tefzel® lined. The housing shall be steel.
1.4	The electronics shall be integrally or remote mounted.
1.5	The integrally-mounted flow sensor and transmitter shall be FM approved for Class I, Division 1 & 2, Groups B, C, D and Class II, Division 1, Groups E, F, G environments without use of air purge. CSA Approved for Class I, Division 2. Optional Cenelec approval available.
1.6	When remote mounted, the flowmeter transmitter shall be furnished in a NEMA-4X enclosure box, with a character, 2-line 16 digit backlit display and 15 feet of cable (standard). Batch controller option available.
1.7	The flowmeter shall be suitable for operation at temperatures from 40°F to 266°F and at pressures from full vacuum to 740 psi.
1.8	Electrodes on Tefzel® liners shall be self-sealing.
1.9	The meter shall incorporate HI-Z circuitry. The preamplifier input impedance shall not be less than 10 ¹² ohms. External ultrasonic electrode cleaners shall not be acceptable.
2.0	Available outputs shall be 1) Isolated analog 4-20 mAdc into 800 ohms (standard); 2) scaled pulse 24 Vdc with selectable 12.5/25/50/100 ms on time, max. freq. 60 Hz.; 3) 0-1000 Hz freq., for 0-100% flow rate. 15 Vdc; 4) two flow alarms; 5) fault, with open collector; 6) RS232 communication; 7) flow direction with open collector; 8) Positive Zero Return (PZR) for external relay contacts. Outputs 2 & 3 can be open collector if required.
2.1	Low flow cutoff shall be selectable from 0-9% of FS and there shall be two flow alarms settable from 0-99% of span. When activated, alarm status shall be indicated on display.
2.2	A 2-line, 16 character backlit alphanumeric display shall indicate user-defined flow units and total flow. All menu advice and commands shall be visible on this display. The display shall be modular and rotatable 360°, in 90° increments. Characters shall be at least 0.125" high for ease of readability.
2.3	The flowmeter shall incorporate the MAG-COMMAND™ feature allowing menu selection and program changes to be made from outside the housing via Hall-effect sensors. It shall not be necessary to remove covers, panels or fasteners to accomplish calibration or program changes.
2.4	The meter software shall incorporate password protection, preventing inadvertent program changes. A hand held programmer is not acceptable.
2.5	The meter shall feature dedicated non-volatile sensor memory (E ² PROM) which shall contain all the characteristics of the sensor (i.e. calibration factors, coil frequency, gain settings) as well as user defined parameters on site. This memory shall facilitate automatic transfer of pre-programmed data to new electronics in the event of a transmitter fault, without requiring renewed calibration/programming.
2.6	All printed circuit boards shall be contained in a single easy plug-in, easy plug out module which is interchangeable with EP electronics from any size meter without requiring any testing or programming.
2.7	The flowmeter shall have a diagnostic feature which will provide a display message and fault output in case of a sensor failure, programming error or empty pipe condition.
2.8	The flowmeter shall have a switching power supply having an operating range from 77 - 265 Vac 50/60 Hz (12-60 Vdc). Power consumption shall not exceed 20 VA.
2.9	The flowmeter shall be furnished with 2 PTFE gaskets.
3.0	The flowmeter manufacturer shall have meters of the DC pulse type in similar flowing mediums for a minimum of ten years.
4.0	The flowmeter shall be warranted against defective workmanship or materials for a period of two years from date of shipment.
5.0	Totalized flow and programmed configuration shall be maintained in memory for the meters lifetime.
6.0	The flowmeter shall be MODEL 626 TigermagEP™ as manufactured by Sparling Instruments, Inc.



4097 N. Temple City Blvd. • P.O. Box 5988 • El Monte, CA USA 91731
Ph (626) 444-0571 • Fx (626) 452-0723
Internet: <http://www.sparlinginstruments.com> • E-mail: sales@sparlinginstruments.com

