

MainLine

Technical Specifications

FM104/184 Electronic Propeller Meter

FT194 Series II Digital Indicator



DESCRIPTION

The Model FM104/184 electronic propeller meter was designed to provide accurate and reliable flow measurement where main line service is required in municipal and industrial areas, where isolation of the drive element from the flowstream is desirable or where durable, cost-effective measurement is required.

All Sparling electronic propeller meters meet C-704 AWWA specifications.

The Model FM104/184 is ideal for potable water, irrigation, water well production, pumping stations and golf course and park water management.

The Model FM104/184 features the FT194-II battery powered electronic rate/totalizer which senses the rotation of the propeller by means of a magnetic pickup sensor located in the gearbox. The rate/totalizer and pickup are completely isolated from the flow stream.

Fewer moving parts combined with proven Sparling design which results in less wear, reduced maintenance costs and longer life.

The FM104/184 Series II is available with an optional 4-20mA dc output for remote totalization using either the Sparling Model 787, 710 or the customer's remote totalizer with 24Vdc power supply. Registration can be changed in the field with the Sparling Model 705 programmer.

PRINCIPLE OF OPERATION

Sparling propeller meters utilize the simple principle of the screw propeller to register the total flow, much as an odometer registers auto mileage. The electronic rate/totalizer converts the revolutions of the propeller to cubic feet, gallons or other standard engineering volumetric units. The rotation of the propeller also affords a basis for indicating and recording gallons per minute or other rates.

STANDARD FEATURES

- $\pm 2\%$ of rate accuracy
- Sizes from 2" - 72"
- NEMA-4X Environmental Ratings
- Accurately measures over a 10:1 flow range
- 8 digit totalizer/indicator
- Display "sleep mode" conserves battery life while continuously totalizing
- Temporary backup power with 4 volt DC battery
- User selectable photocell light sensitivity from low to bright

OPTIONAL FEATURES

- 4-20 mA dc output
- Remote Mounted Totalizer - up to 50 ft. from meterhead
- Scaled pulse output

MATERIALS

- Cover Plate: Cast Iron
- Propeller: Molded Polyethylene
- Gearbox: Brass up to 30" & Cast Iron above 30"
- Bearings: SST or Rubber (high speed)
- Coating: Epoxy based paint (potable water approved)

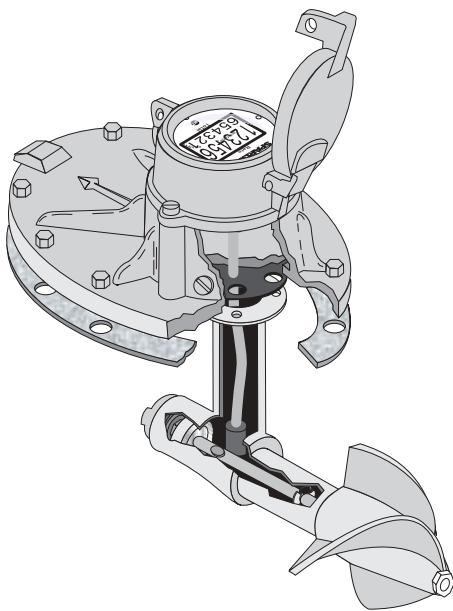

Figure 1
Principle of Operation

EASY TO REPAIR

The FM104/184 is easily repaired with common hand tools. No special tools are required.

TEMPERATURE LIMITS

Liquid working temperature should not exceed 100°F. Propellers may be stored in air temperatures up to 175°F. Optional high temperature construction is available for liquid temperatures up to 200°F.

FLOW RANGES

The FM104/184 propeller meter measures accurately over a wide flow range of 10:1 or greater. Meters are available with factory fabricated tubes, saddles, or as a meterhead assembly. The totalizer may be integral or remote mounted.

Your Sparling meter utilizes specially designed propellers and bearings matched to your flow range to insure a long life. Maximum flow ranges can be safely exceeded by 50% when used intermittently. See the Flow Range chart on Page 4.

Anticipated flow ranges, including minimum and normal flow rates expected should always be specified on application sheets accompanying your order for proper configuration of meter construction.

OUTPUTS

Optional outputs include 4-20mAdc, scaled pulse output (open collector).

INSTALLATION

Meters must be installed in full flowing suction or discharge lines. Avoid valves, fittings or obstructions immediately upstream of the meter which may cause jetting or non-symmetrical flow profiles. It is recommended that a minimum of five straight pipe diameters be maintained upstream and one diameter downstream of the flow meter.

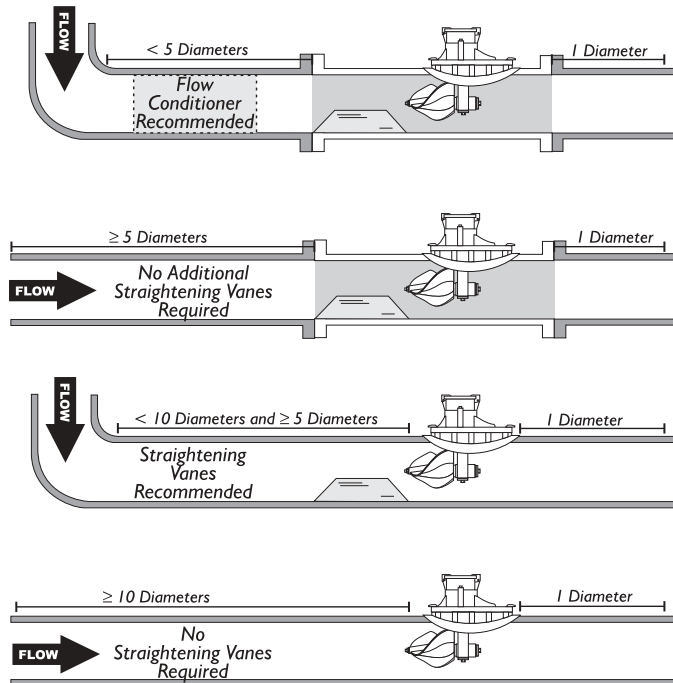

Figure 2
Installation Considerations

FT194-II DIGITAL RATE/TOTALIZER

The FT194-II is a digital flow rate and totalizer with an easy to read LCD display which features simultaneous rate and totalizer indication. *The FT194-II is standard on the FM104/184 but may also be retrofit to existing Sparling meters see Figure 4.*

A non-volatile memory holds all meter parameters such as full scale, span, calibration factors, engineering units, damping parameters and flow totals, even in the event of a power failure.

A photoelectric cell activates the display when the cover is opened. After a user programmed time interval the display reverts to an energy saving "sleep mode" while continuing to track total flow. To reactivate the display, simply close and open the cover. The 3.6V lithium battery has a 3 year average life. A low battery indication will display before battery requires replacement. Low battery display will not affect totalization accuracy.



REMOTE MOUNTED TRANSMITTER

For remote indication of rate and total the FT194-II display/transmitter may be mounted up to 50 ft. from the meter head. This is ideal for situations where it is inconvenient to have the indicator mounted integrally to the meterhead, such as a pit or frequently flooded area. See Figure 3.

The remote totalizer is furnished ready to bolt to a wall or customer supplied plate. Optional U-bolts can be obtained for pipe mounting. 15 feet of cable is supplied standard with the remote unit. Additional cable, up to 50 feet total, may be purchased when the order is placed.

The optional 4-20mAdc and scaled pulse output require connection to a customer supplied 24Vdc power supply.

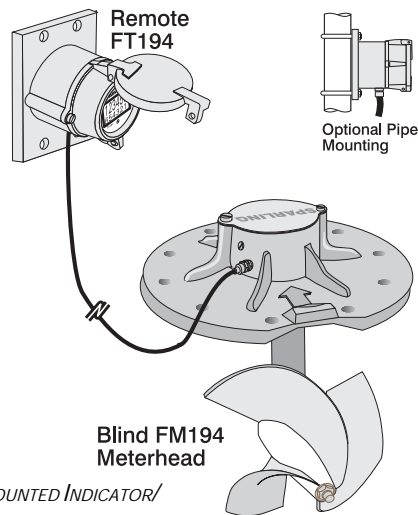

FIGURE 3
REMOTE MOUNTED INDICATOR/
TOTALIZER

You may also use Series 710 Local and Remote Indicator/Totalizer

FT194-II RETROFIT AVAILABLE FOR YOUR EXISTING SPARLING METERS

Sparling's factory technicians can upgrade your existing Sparling propeller meters to the new FT194-II indicator/totalizer. You'll have all the benefits of the Model 104/184 Propeller Meter: fewer moving parts, digital readout and longer life.

Sparling factory technicians remove the vertical shaft and inspect the propeller shaft, bearings and bushings to insure proper operation. The magnetic sensor pickup, which is completely potted and isolated from moisture, is then inserted into the gearbox and the electronic indicator totalizer is mounted to the meter body. Finally the meter is wet flow calibrated at a minimum of three test points.

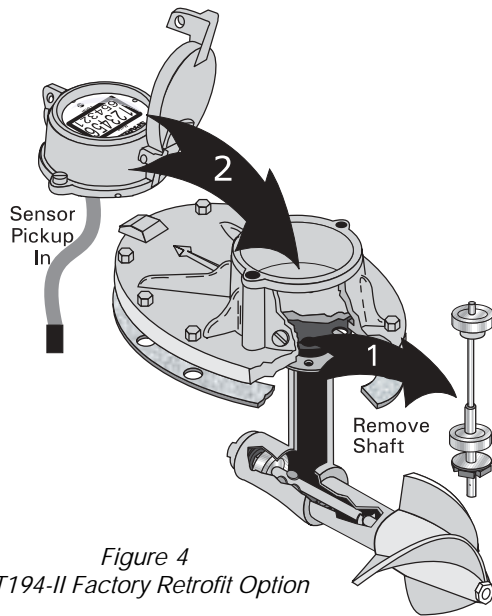
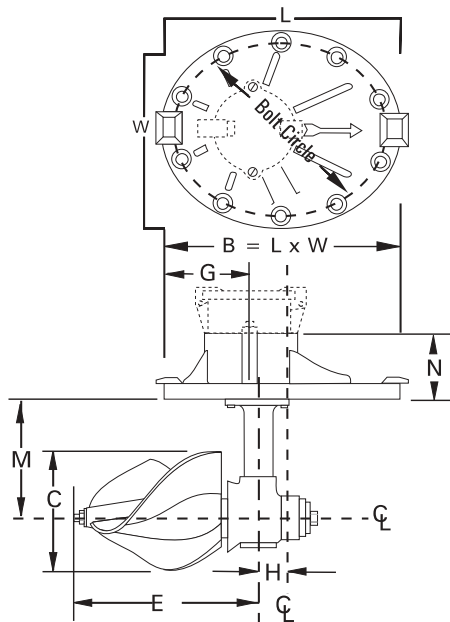
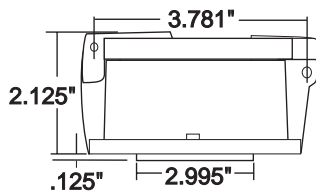

Figure 4
FT194-II Factory Retrofit Option

FM104



FT194-II



FM184

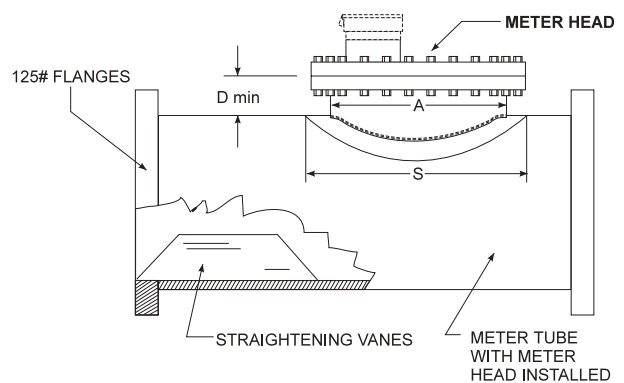
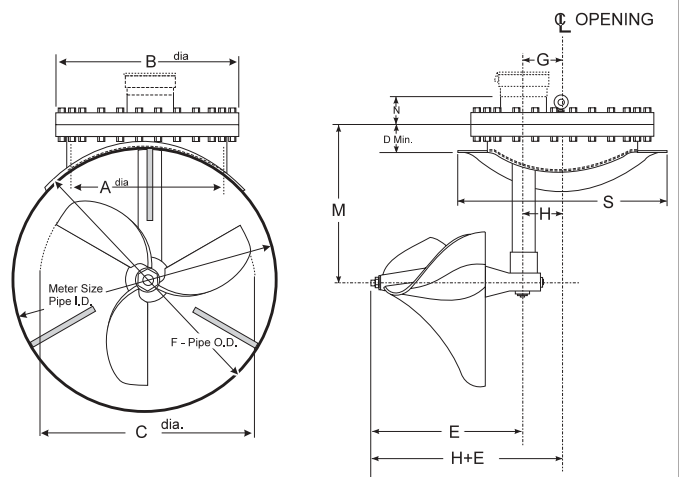

For detailed metering tube dimensions please visit our website: sparlinginstruments.com and download PDS-110 Propeller Meter Tubes & Saddles

TABLE 1 - FLOW & DIMENSIONS

Size	Fabr. Steel	Cast Iron	B		C	D	E	G	H	M		N	S	Low Flow		Std. Flow		Size of Bolts	# of Bolts
			150 lbs.	250 lbs.						150 lbs.	250 lbs.			Min.	Max.	Min.	Max.		
2	-	20	-	8.13 x 5.13	2.38	-	4.00	3.13	0.50	1.75	1.75	2.56	-	30 - 80	60 - 150	-	-	-	-
3	-	20	-	8.25 x 6.25	2.75	-	4.00	3.18	0.63	2.75	2.75	2.56	-	35 - 200	70 - 360	-	-	-	-
4	20	-	-	9.50 x 6.75	3.50	-	6.94	4.13	0.63	3.44	3.44	2.56	-	50 - 400	120 - 600	-	-	-	-
6	25	-	-	10.38 x 7.31	4.75	-	6.31	3.69	0.94	4.25	4.25	2.93	-	90 - 900	200 - 1600	-	-	-	-
8	29	-	-	11.00 x 10.63	7.00	-	6.31	5.81	-0.32	5.31	5.31	2.81	-	100 - 1200	240 - 2300	-	-	-	-
10	34	-	-	11.00 x 10.63	8.00	-	6.31	5.81	-0.32	6.31	6.31	2.81	-	125 - 1600	320 - 3000	-	-	-	-
12	36	-	-	11.00 x 10.63	10.00	-	6.31	5.81	-0.32	7.31	7.31	2.81	-	150 - 2200	400 - 4000	-	-	-	-
14	37	-	-	11.00 x 10.63	11.00	-	6.31	5.81	-0.32	8.00	8.00	2.81	-	250 - 3000	520 - 5000	-	-	-	-
16	210	-	16.00	23.50 dia.	13.00	4.00	12.00	4.56	4.25	12.25	12.25	2.88	N/A	350 - 3800	700 - 6800	1.00	16	16	16
18	210	-	16.00	23.50 dia.	16.00	4.50	12.00	4.56	4.25	13.25	13.50	2.88	26.00	450 - 4500	900 - 8100	1.00	16	16	16
20	215	-	16.00	23.50 dia.	16.00	4.00	12.00	4.56	4.25	14.25	14.50	2.88	26.00	550 - 5500	1100 - 9900	1.00	16	16	16
24	215	-	16.00	23.50 dia.	16.00	4.50	12.00	4.56	4.25	16.25	16.50	2.88	26.00	800 - 8500	1600 - 15000	1.00	16	16	16
30	220	-	16.00	23.50 dia.	16.00	4.50	12.00	4.56	4.25	19.25	19.50	2.88	26.00	1200 - 12000	3000 - 21600	1.00	16	16	16
36	825	-	24.00	32.00 dia.	25.25	5.00	18.75	6.81	6.50	23.00	24.00	3.13	36.50	1500 - 16000	3000 - 28800	1.25	20	20	20
42	835	-	24.00	32.00 dia.	25.25	5.00	18.75	6.81	6.50	26.00	27.00	3.13	36.50	2000 - 22000	4200 - 40000	1.25	20	20	20
48	1350	-	30.00	38.75 dia.	25.25	5.50	20.00	9.81	9.50	29.50	30.50	3.25	46.75	2500 - 28000	5400 - 50000	1.25	28	28	28
54	1360	-	30.00	38.75 dia.	25.25	5.50	20.00	9.81	9.50	32.50	33.50	3.25	46.75	3200 - 35000	6800 - 63000	1.25	28	28	28
60	1370	-	30.00	38.75 dia.	25.25	5.50	20.00	9.81	9.50	35.50	36.50	3.25	46.75	4000 - 42000	8400 - 76000	1.25	28	28	28
66	1380	-	30.00	38.75 dia.	25.25	5.50	20.00	9.81	9.50	38.50	39.50	3.25	46.75	4750 - 50000	10000 - 90000	1.25	28	28	28
72	1390	-	30.00	38.75 dia.	25.25	5.50	20.00	9.81	9.20	41.50	42.50	3.25	46.75	5500 - 60000	12000 - 110000	1.25	28	28	28

Maximum flow ranges can be safely exceeded by 50% when used intermittently (10-15% of the time). Your Sparling meter utilizes specially designed propellers and bearings matched to your flow range to insure long life. For proper configuration of meter construction anticipated flow ranges, including minimum and normal flow rates expected, should always be specified on application sheets accompanying your order.

TABLE 2 - STANDARD REGISTRATION FOR FT194

Nom. Size	Cubic Feet	U.S. Gallons	Imperial Gallons	Acre Feet	Cubic Meters	Liters
2	1.0	10.0	10.0	0.00001	0.01	10.0
3	1.0	10.0	10.0	0.0001	0.1	100.0
4	10.0	100.0	100.0	0.0001	0.1	100.0
5	10.0	100.0	100.0	0.0001	0.1	100.0
6	10.0	100.0	100.0	0.001	1.0	100.0
8	10.0	100.0	100.0	0.001	1.0	1000.0
10	100.0	100.0	100.0	0.001	1.0	1000.0
12	100.0	1000.0	1000.0	0.001	1.0	1000.0
14	100.0	1000.0	1000.0	0.001	1.0	1000.0
16	100.0	1000.0	1000.0	0.01	10.0	10000.0
18	100.0	1000.0	1000.0	0.01	10.0	10000.0
20	100.0	1000.0	1000.0	0.01	10.0	10000.0
24	100.0	1000.0	1000.0	0.01	10.0	10000.0
30	100.0	1000.0	1000.0	0.01	10.0	10000.0
36	1000.0	10000.0	10000.0	0.01	10.0	10000.0
42	1000.0	10000.0	10000.0	0.01	10.0	10000.0
48	1000.0	10000.0	10000.0	0.1	100.0	100000.0
54	1000.0	10000.0	10000.0	0.1	100.0	100000.0
60	1000.0	10000.0	10000.0	0.1	100.0	100000.0
66	1000.0	10000.0	10000.0	0.1	100.0	100000.0
72	1000.0	10000.0	10000.0	0.1	100.0	100000.0

HOW TO ORDER A MAINLINE FM 104/184

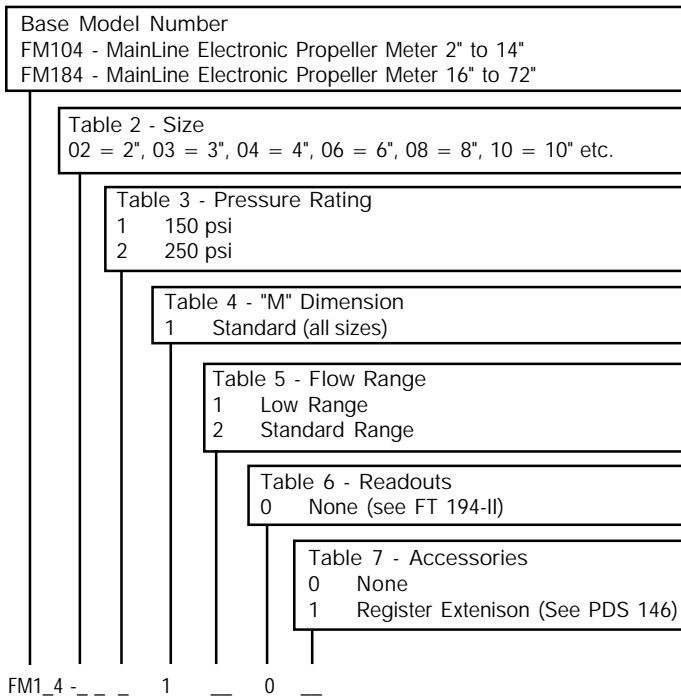

HOW TO ORDER A MAINLINE FT 194-II

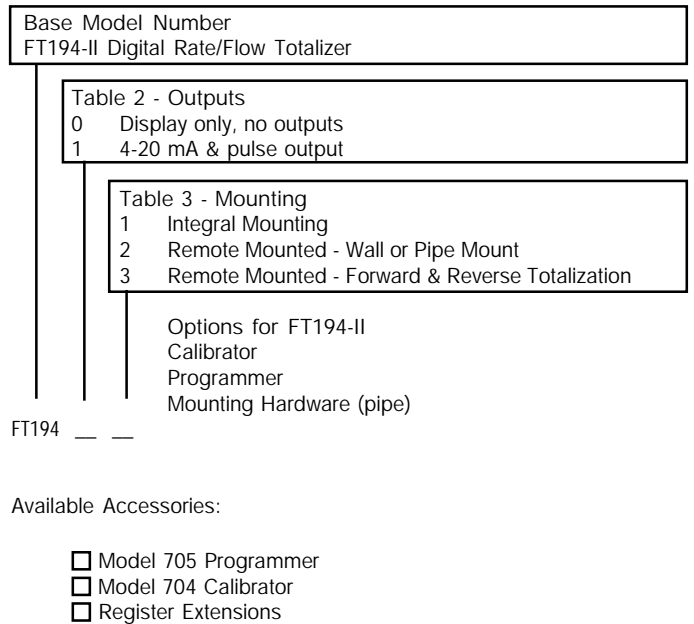

Important: This meter requires a metering tube or saddle to complete installation.

FM104/184 SAMPLE SPECIFICATION

2" – 72" Electronic Propeller Meters - General

- 1.0 The propeller meter shall be designed to operate continuously at any flow rate within the rated range. The propeller meter shall be able to operate at 150% of the maximum for short periods of time not greater than 10% - 15% of the time.
- 1.1 The propeller meter accuracy shall be $\pm 2\%$ of rate at any flow from the minimum rating to 150% of maximum rating.
- 1.2 The propeller meter shall be wet flow calibrated against a primary standard accurate to $\pm 0.50\%$ or better traceable to the National Institute of Standards and Technology.
- 1.3 Two certified copies of the calibrations shall be furnished to the engineer. Flow rates shall be taken at or near minimum flow rating, at mid-range and at the highest flow rate within the range attainable by the test facility.

Meter head

- 2.0 The meter head shall be mounted on a flanged connection for ease of removal from the pipe for inspection or service.
- 2.1 Meter head construction shall consist of a cast iron cover plate, bronze gear box, machined stainless steel parts, hard rubber wetted working parts and polyethylene propeller.
- 2.2 The drive mechanism shall consist of stainless steel shaft embedded with magnets that function with a magnetic pickup to record propeller rotation.
- 2.3 Meter heads which utilize flexible cable drives between the propeller and the readout device shall not be accepted.
- 2.4 Bearings shall be constructed of stainless steel or rubber. Ceramic bearings shall not be acceptable.
- 2.5 The meters shall be as manufactured by Sparling Instruments, Inc. Model FM 104/184.

Flanged Tube or Saddle

- 3.0 2" to 3" meter heads will be furnished with cast iron tubes lined with stainless steel liner at the metering section and AWWA class D flat face flanges.
- 3.1 4" to 36" meter heads shall be furnished with fabricated steel flanged tubes with straightening vanes. These shall be protected by the manufacturer's standard protective coating or lined and coated with a seven mil thick coating of polyamide hi-build epoxy.
- 3.2 6" to 72" meter heads are available with welding saddles to match to existing pipes for field retrofit.
- 3.3 4" to 36" meter tubes shall be fabricated of carbon steel with AWWA class D flanges.

Electronic Register - FT 194-II

- 4.0 The electronic register shall be equipped with simultaneous rate and totalizer display. The electronics and display shall be protected by an all metal register box and cover with locking hasp. Both flow rate and total indicators shall be on the meter register face and indicate simultaneously.
- 4.1 The electronic register shall have a low battery LCD indication which indicates the battery must be changed.
- 4.2 The electronic register housing shall meet the specifications for NEMA-4X.
- 4.3 The electronic register shall be capable of being remote mounted up to 50 feet from the propeller meter head and shall be able to provide open collector totalizer output.
- 4.4 The electronic register shall have the option of providing a 4-20mA rate output and a scaled pulse for totalization programmable by the user when the unit is powered with 24 VDC power supply.
- 4.5 The electronic register shall have an 3 year battery life. A photo-electric cell shall turn the indicator on and off. The indicator will power up when the cover is opened. The indicator shall go into a sleep mode after a programmed amount of time and will not indicate unless the cover is closed and then opened. The register shall shut off at the programmed time whether the cover is open or shut. The on-time of the indicator shall be programmable by the user with a programming box available from the manufacturer. The totalizer shall continue totalizing during sleep mode.
- 4.6 The totalizer shall retain the total in memory for 10 years if the battery is not functioning or removed. For forward and reverse flow, two separate units shall be provided.
- 4.7 The electronic register shall totalize only in one direction, ignoring reverse flow through the meter.
- 4.8 Engineering units are available in gallons, cubic feet, cubic meters, liters, acre feet or any other engineering units specified by the user. Any units of time from seconds, minutes, hours or days may be used in the rate calculations.
- 4.9 The totalizer and all other user programmable items shall be reset in the field with a programmer available from the manufacturer.
- 4.10 The electronic register enclosure shall be cast aluminum with a locking hasp. Plastic enclosures shall be unacceptable for the register.

Manufacturer

- 5.0 The meters shall be as manufactured by Sparling Instruments, Inc., model FT 194-II for the register and model FM 104/184 for the propeller meter.

Specifications subject to change without notice.



4097 N. Temple City Blvd. • P.O. Box 5988 • El Monte, CA USA 91731
Ph (626) 444-0571 • Fx (626) 452-0723
www.sparlinginstruments.com • email: sales@sparlinginstruments.com

